

COMPACT
disc
DIGITAL AUDIO

Artistry in Sound
ONKYO[®]

DX-788F

Compact Disc Player

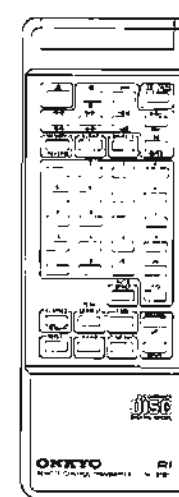
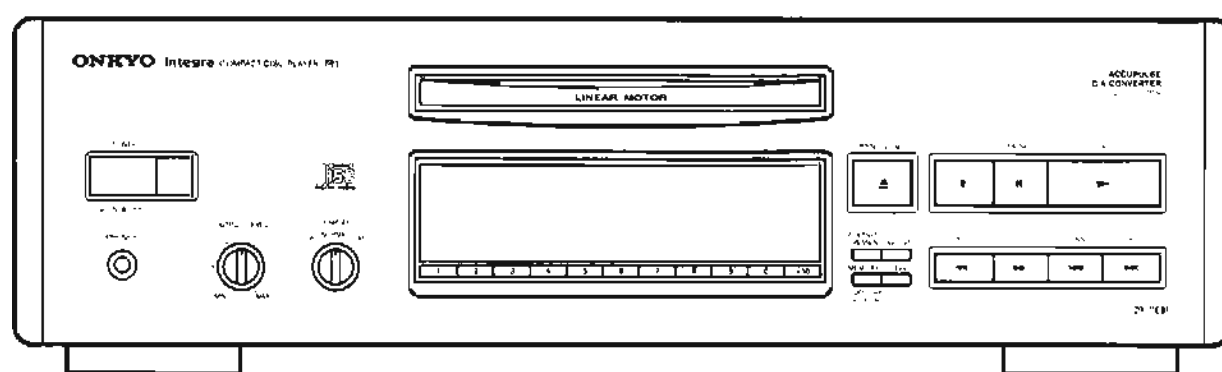

ONKYO Integra

Instruction Manual

- *Congratulations on your purchase of the ONKYO DX-788F CD player.*
- *Please read this manual thoroughly before making connections and turning power on.*
- *Follow these instructions to obtain optimum performance and maximum listening enjoyment from your new DX-788F.* ● *Please retain this manual for future reference.*

Contents

Features	2	Playing CDs	12-13
Important safeguards	3	Normal play	12
Precautions	5	Basic operation	13
Before using this unit	6-7	Playing CDs	14-15
Supplied accessories	6	Convenient features	14
Releasing the transport lock	6	Using memory play	16-17
Inserting the remote control batteries	7	Storing a program into memory and play	16
Handling compact discs	7	Convenient recording features	18-19
System connections	8-9	Peak Search Function	18
Connecting the CD player to your amplifier	8	Fade Out/Auto Space Function	18
Connecting the remote control cable	9	Time Edit Function	19
Connecting and using a timer	9	Troubleshooting guide	20
Identifying buttons and indicators	10-11	Specifications	20
Looking at the front panel and display window	10		
Looking at the remote control	11		

Features

■ FPCS (Fine Pulse Conversion System)

In an effort to improve the quality of digital music, ONKYO investigated the reasons behind CD's lack of "warmth" or "musicality" and found that conventional interpolation methods emphasize frequency response. Thus ONKYO developed an entirely new method of interpolation (FPCS), based on techniques borrowed from the latest advances in computer graphic technology. The result is smoother interpolation and warmer, more "musical" sounding music.

■ ONKYO's AccuPulse Quartz System

Because of their high speed, pulse converters require perfect synchronization to do their job properly. ONKYO's proprietary AccuPulse Quartz System maintains this synchronization with uncommon accuracy, thereby eliminating distortion-causing jitter, and giving ONKYO an audible advantage over other pulse converters.

■ Complementary Distortion Canceler

Two PDM (pulse density modulation) outputs are obtained, one with the phase reversed, and applied to a differential amplifier. This eliminates all PDM distortion and provides a pristine analog output signal.

■ Totally Balanced Output Topology

Rather than the simpler unbalanced circuit designs widely used in many components, the DX-788F boasts totally balanced, double-amp construction from the D/A converter output stages. This shuts out common-mode noise, and allows more room for the music signal.

■ Advanced Dual AEI Transformers

ONKYO's AEI (anti-electromagnetic interference) transformers' special core configuration and silicon-steel shielding reduce distortion-causing magnetic flux leakage from 1/10 to 1/20 the levels associated with conventional EI transformers, and help to maximize optimum performance from the balanced output circuitry.

■ Eight-Times Oversampling

■ Center Mounted Die-Cast Aluminum Disc Tray & Linear Slide Motor Mechanism

■ Peak Search

■ Memory Reverse

■ 5-Mode Repeat

■ Shuffle Play

■ Front Panel Dimmer Switch

■ 4-Mode Time Display

■ Copper Plated Chassis

■ Optical Digital Output (with ON/OFF switch)

■ RI Compatible Remote Control Supplied

“WARNING”

“TO REDUCE THE RISK OF FIRE OR ELECTRIC SHOCK, DO NOT EXPOSE THIS APPLIANCE TO RAIN OR MOISTURE.”

CAUTION

“TO REDUCE THE RISK OF ELECTRIC SHOCK, DO NOT REMOVE COVER (OR BACK). NO USER-SERVICEABLE PARTS INSIDE. REFER SERVICING TO QUALIFIED SERVICE PERSONNEL.”



- The lightning flash with arrowhead symbol, within an equilateral triangle, is intended to alert the user to the presence of uninsulated “dangerous voltage” within the product’s enclosure that may be of sufficient magnitude to constitute a risk of electric shock to persons.



- The exclamation point within an equilateral triangle is intended to alert the user to the presence of important operating and maintenance (servicing) instructions in the literature accompanying the appliance.

Important safeguards

1. **Read Instructions** – All the safety and operating instructions should be read before the appliance is operated.
2. **Retain Instructions** – The safety and operating instructions should be retained for future reference.
3. **Heed Warnings** – All warnings on the appliance and in the operating instructions should be adhered to.
4. **Follow Instructions** – All operating and use instructions should be followed.
5. **Water and Moisture** – The appliance should not be used near water - for example, near a bathtub, washbowl, kitchen sink, laundry tub, in a wet basement, or near a swimming pool, and the like.
6. **Carts and Stands** – The appliance should be used only with a cart or stand that is recommended by the manufacturer.
- 6A. An appliance and cart combination should be moved with care. Quick stops, excessive force, and uneven surfaces may cause the appliance and cart combination to overturn.
7. **Wall or Ceiling Mounting** – The appliance should be mounted to a wall or ceiling only as recommended by the manufacturer.
8. **Ventilation** – The appliance should be situated so that its location or position does not interfere with its proper ventilation. For example, the appliance should not be situated on a bed, sofa, rug, or similar surface that may block the ventilation openings or, placed in a built-in installation, such as a bookcase or cabinet that may impede the flow of air through the ventilation openings.
9. **Heat** – The appliance should be situated away from heat sources such as radiators, heat registers, stoves, or other appliances (including amplifiers) that produce heat.

PORTABLE CART WARNING



S3125A

FOR CANADIAN MODEL:
(POUR LE MODELE CANADIEN:)

- For models having power cord with a polarized plug.

CAUTION: TO PREVENT ELECTRIC SHOCK, MATCH WIDE BLADE OF PLUG TO WIDE SLOT, FULLY INSERT.

- Sur les modèles dont la fiche est polarisée.

ATTENTION: POUR ÉVITER LES CHOCS ÉLECTRIQUES, INTRODUIRE LA LAME LA PLUS LARGE DE LA FICHE DANS LA BORNE CORRESPONDANTE DE LA PRISE ET POUSSER JUSQU’AU FOND.

10. **Power Sources** – The appliance should be connected to a power supply only of the type described in the operating instructions or as marked on the appliance.
11. **Polarization** – If the appliance is provided with a polarized plug having one blade wider than the other, please read the following information; The polarization of the plug is a safety feature. The polarized plug will only fit the outlet one way. If the plug does not fit fully into the outlet, try reversing it. If there is still trouble, the user should seek the services of a qualified electrician. Under no circumstances should the user attempt to defeat the polarization of the plug.
12. **Power-Cord Protection** – Power-supply cords should be routed so that they are not likely to be walked on or pinched by items placed upon or against them, paying particular attention to cords at plugs, convenience receptacles, and the point where they exit from the appliance.
13. **Cleaning** – The appliance should be cleaned only as recommended by the manufacturer.
14. **Nonuse Periods** – The power cord of the appliance should be unplugged from the outlet when left unused for a long period of time.
15. **Object and Liquid Entry** – Care should be taken so that objects do not fall and liquids are not spilled into the enclosure through openings.
16. **Damage Requiring Service** – The appliance should be serviced by qualified service personnel when:
 - A. The power-supply cord or the plug has been damaged or
 - B. Objects have fallen, or liquid has been spilled into the appliance or
 - C. The appliance has been exposed to rain or
 - D. The appliance does not appear to operate normally or exhibits a marked change in performance or
 - E. The appliance has been dropped or the enclosure damaged.
17. **Servicing** – The user should not attempt to service the appliance beyond that described in the operating instructions. All other servicing should be referred to qualified service personnel.

ONKYO Integra

SPECIAL CAUTIONS FOR COMPACT DISC PLAYER

- This Compact Disc Player contains a semiconductor laser system and is classified as a "CLASS 1 LASER PRODUCT". So, to use this model properly, read this Owner's Manual carefully. In case of any trouble, please contact the store where you purchased the unit. To prevent being exposed to the laser beam, do not try to open the enclosure.
- The laser is covered by a housing which prevents exposure during operation or maintenance. However, this product is classified as a Laser Product by CDRH (Center for Devices and Radiological Health) which is a department of the Food and Drug Administration. According to their regulations 21 CFR section 1002.30, all manufacturers who sell Laser Products must maintain records of written communications between the manufacturer, dealers and customers concerning radiation safety. If you have any complaints about instructions or explanations affecting the use of this product, please feel free to write to the address on the back page of this manual. When you write us, please include the model number and serial number of your Compact Disc Player.
- In compliance with Federal Regulations, the certification, identification and the period of manufacture are indicated on the rear panel.

- **DANGER:**
INVISIBLE LASER RADIATION CAN OCCUR WHEN THE PLAYER IS OPEN AND THE INTERLOCK HAS FAILED OR IS DEFEATED. AVOID DIRECT EXPOSURE TO BEAM.

- **CAUTION:**
THIS PRODUCT UTILIZES A LASER. USE OF CONTROLS, OR ADJUSTMENTS, OR PERFORMANCE OF PROCEDURES OTHER THAN THOSE SPECIFIED HEREIN MAY RESULT IN HAZARDOUS RADIATION EXPOSURE.

- **FCC INFORMATION FOR USER**

CAUTION:

Changes or modifications not expressly approved by the party responsible for compliance could void the user's authority to operate the equipment.

NOTE:

This equipment has been tested and found to comply with the limits for a Class B digital device pursuant to Part 15 of the FCC Rules. These limits are designed to provide reasonable protection against harmful interference in a residential installation. This equipment generates, uses and can radiate radio frequency energy and if not installed and used in accordance with the instructions may cause harmful interference to radio communications. However there is no guarantee that interference will not occur in a particular installation. If this equipment does cause harmful interference to radio or television reception, which can be determined by turning the equipment off and on, the user is encouraged to try to correct the interference by one or more of the following measures:

- Reorient or relocate the receiving antenna.
- Increase the separation between the equipment and receiver.

- Connect the equipment into an outlet on a circuit different from that to which the receiver is connected.
- Consult the dealer or an experienced radio/TV technician for help.

FOR CANADIAN MODEL (POUR LE MODELE CANADIEN)

- THIS DIGITAL APPARATUS DOES NOT EXCEED THE CLASS B LIMITS FOR RADIO NOISE EMISSION FROM DIGITAL APPARATUS SET OUT IN THE RADIO INTERFERENCE REGULATIONS OF THE CANADIAN DEPARTMENT OF COMMUNICATIONS.
- L'INTERFERENCE, RADIO ELECTRIQUE GENEREE PAR CET APPAREIL NUMERIQUE DE TYPE B NE DEPASSE PAS LES LIMITES ENONCEES DANS LE REGLEMENT SUIVANT LES PERTURBATIONS RADIO ELECTRIQUES, SECTION APPAREIL NUMERIQUE, DU MINISTERE DES COMMUNICATIONS.

Precautions

1. Warranty Card

The serial number is written on the rear panel of this unit. Copy the serial number and model number onto your warranty card and keep it in a safe place.

2. Power

WARNING

BEFORE TURNING ON POWER FOR THE FIRST TIME, READ THE FOLLOWING SECTION CAREFULLY.

- Some models are designed for use only with the power supply voltage of the region where they are sold.
U.K. and Australian models: AC 240V, 50Hz
European model (except U.K.): AC 230V, 50 Hz
U.S.A. and Canadian models: AC 120V, 60 Hz
Worldwide model: AC 120V/220V
switchable, 50/60 Hz
- Voltage Selector (Rear Panel)
Worldwide models are equipped with a voltage selector to conform with local power supplies. Be sure to set this switch to match the voltage of the power supply in your area before turning the power button on. (See "Setting the voltage selector [worldwide models only]", p. 9.) Models without a voltage selector can only be used in areas where the power supply is the same as that of the unit.

3. Do Not Touch the Player with Wet Hands

Do not handle the player or power cord when your hands are wet or damp. If water or any other liquid enters the player cabinet, take the player to an authorized service station for inspection.

4. Location of the Player

- Place the Player in a Well-Ventilated Location.
Take special care to provide plenty of ventilation on all sides of the player especially when it is placed in an audio rack. If ventilation is blocked, the player may overheat and malfunction.
- Do not expose the player to direct sunlight or heating units as the player's internal temperature may rise and shorten the life of the pickup.
- Avoid damp and dusty places and places directly affected by vibrations from the speakers. In particular, avoid placing the unit on or above one of the speakers.
- Be sure the player is placed in a horizontal position. Never place it on its side or on a slanted surface as it may malfunction.
- Do Not Place Near Tuners and TV Sets.
If placed next to a TV or other tuner, it may cause reception interference resulting in some noise in the TV or tuner output.

5. Care

From time to time you should wipe off the front and rear panels and the cabinet with a soft cloth. For heavier dirt, dampen a soft cloth in a weak solution of mild detergent and water, wring it out dry, and wipe away the dirt. Following this, dry immediately with a clean cloth. Do not use rough material, thinners, alcohol or other chemical solvents or cloths since these may damage the finish or remove the panel lettering.

6. Points to Remember

- If the player is brought from a cold environment to a warm one or is in a cold room that is quickly heated, dew may form on the pickup, preventing proper operation. In this case, remove the disc and leave the power ON for about one hour to remove the dew.
- Always close the disc tray when not loading or unloading discs to protect delicate internal parts from dust.
- When transporting the player, be careful not to bump it.

Before using this unit

Supplied accessories

Check to see that you received the supplied accessories shown below. If you did not receive all the accessories, contact your ONKYO authorized service center.



2 Balanced line cable

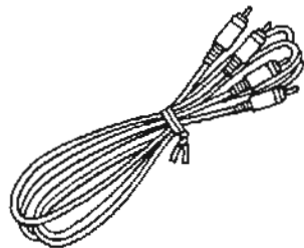

1 Audio connection cable



1 **RI** remote control cable

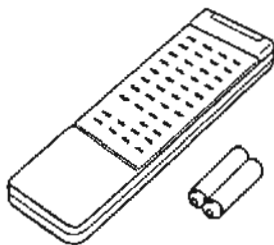

1 Remote control
2 Batteries (size AA, or R6, or UM-3)

Releasing the transport lock

To protect the optical assembly including the laser pickup from vibration related damage during shipping, this unit is equipped with a transport lock lever located on the base.

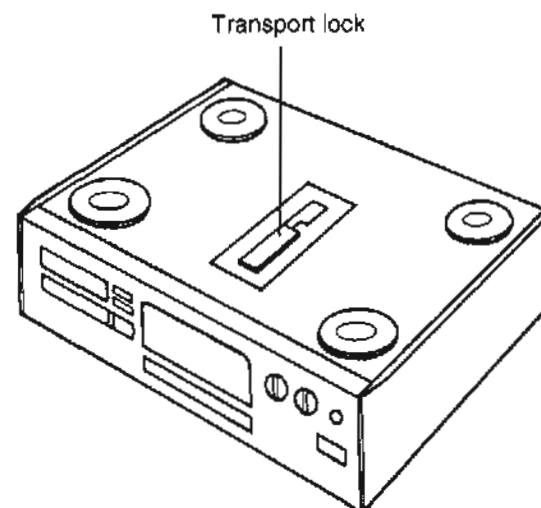

How to release the transport lock

1. Loosen the screw with a Phillips screwdriver.
2. Move the lock lever in the opposite direction to that shown by the arrow. Move the lever up to the position where it can move no farther.
3. Then re-tighten the screw into lock lever screw hole.

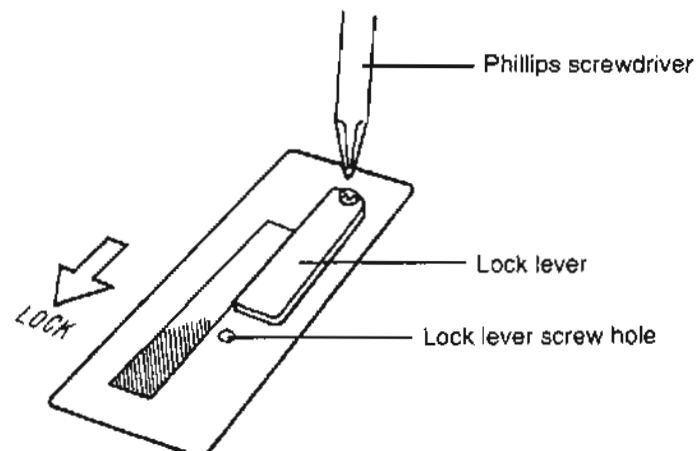

Tighten the screw to secure the lock lever.

For shipping, turn the lock lever to its position in the direction of the arrow, then tighten down the screw to secure the lock lever in that position.

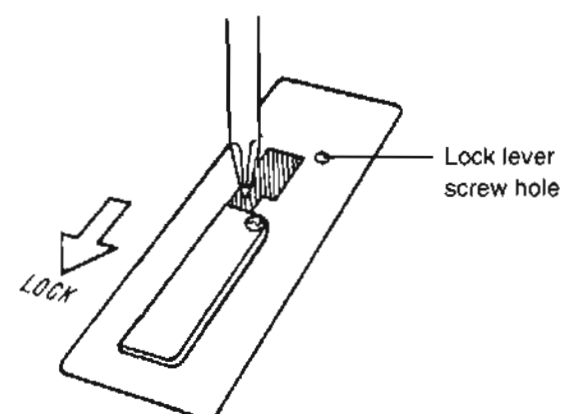

Inserting the remote control batteries

1.

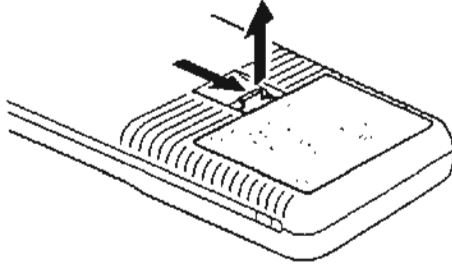

Push the battery cover tab on the back of the remote control in the direction of the arrow and lift it up.

2.

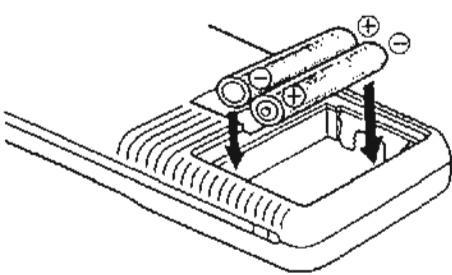

Insert the batteries with the + and - ends facing in the directions illustrated.

3.

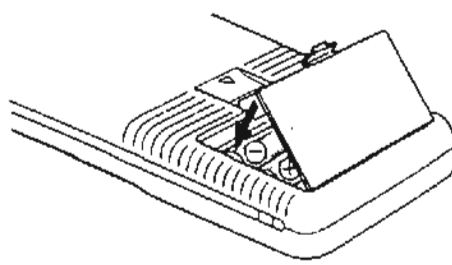

Put the battery cover back in place.

Average battery life is about one year, depending upon the frequency of use and the environment (temperature and humidity) in which the remote control is used. Only use batteries of the kind specified in the table below.

Type	Voltage	Size
Manganese	1.5V	AA, R6 or UM-3

Warning

- Do not leave an expired battery in the case – it may leak or damage the remote control.
- Do not use nickel cadmium (rechargeable) batteries.
- Replace both batteries at once; do not use one old battery and one new battery.

Handling compact discs

1.

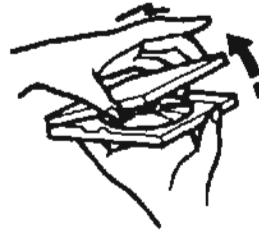

Hold the disc case in the palm of one hand and pull the lid up and backward.

2.



Push down on the inside of the disc case, through the center hole of the disc.

3.

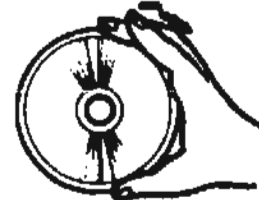

Carefully lift the disc from the disc case, making sure to hold the disc by the edges only.



- A dry, soft cloth may be used to wipe dust and fingerprints off the surface of CDs. Do not use volatile agents on discs, such as thinner or benzine. Also, do not use conventional record cleaner or antistatic agents.
- Do not place a CD in direct sunlight or locations subject to high humidity or low temperature.
- Do not store a CD in the CD player tray for long periods of time.

System connections

Connecting the CD player to your amplifier

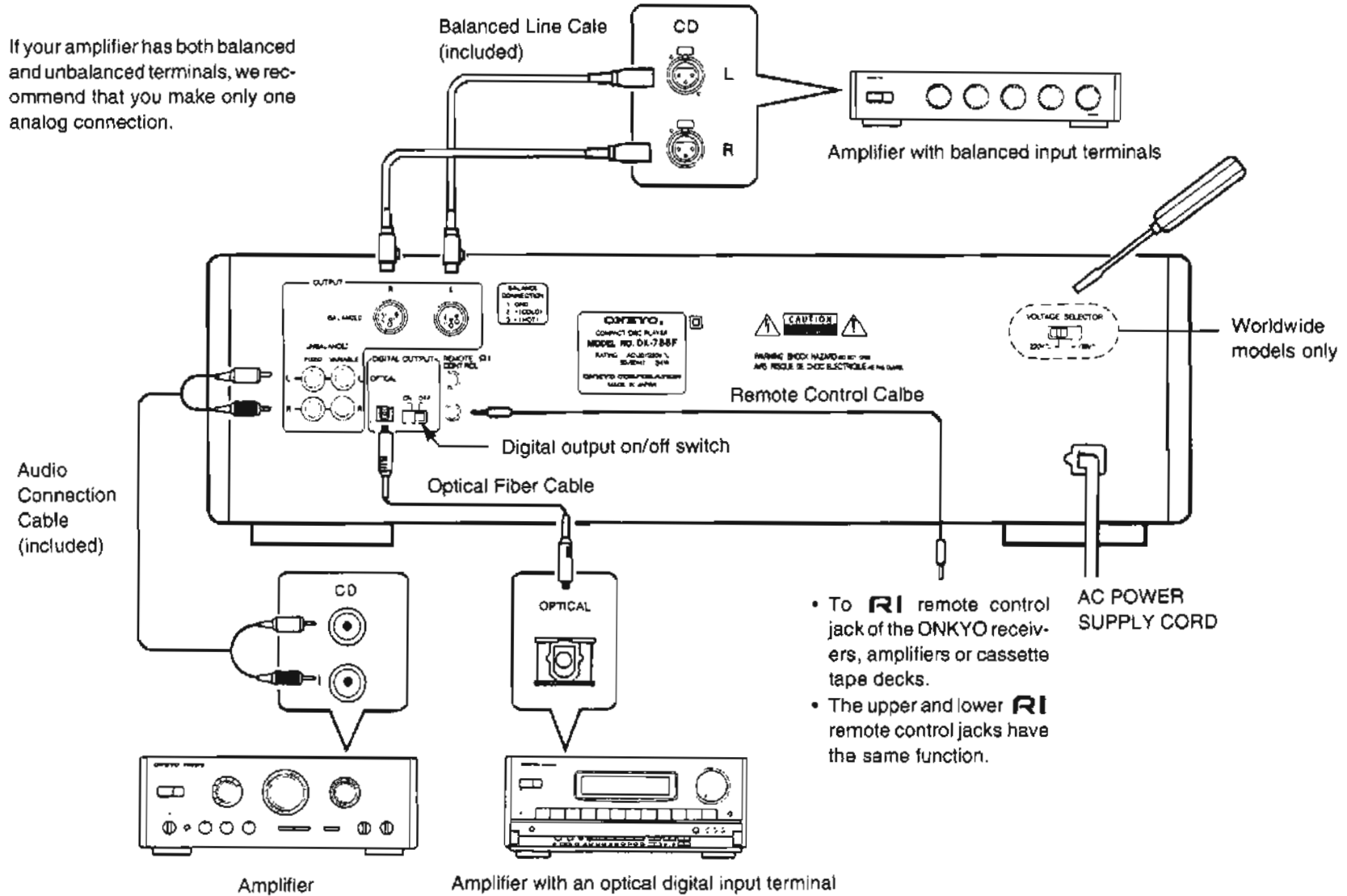
- Do not plug in the power cord until the CD player is completely connected to your system.
- Three types of output jacks are located on the rear panel. Select the appropriate type according to your amplifier.

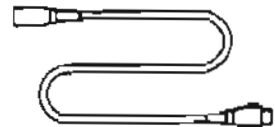

Type	Rear panel name	Description	Cable to be used.
Analog	UNBALANCED	These are the terminals which will probably be commonly used. When connecting, use the supplied Audio Connection cable. You can select either the FIXED or VARIABLE terminals. FIXED : the output level cannot be changed. VARIABLE : the output level can be controlled using the OUTPUT LEVEL knob on the front panel or the VOLUME UP/DOWN buttons on the remote control.	 Audio Connection cable (Included)
	BALANCED	These terminals are used to connect the CD player to an amplifier which has balanced input terminals. The output impedance is 200Ω. This terminal is equivalent to XLR-3-32. Suitable connectors are XLR-3-11C equivalent products. Pin polarity 1 : GND 2 : - (COLD) 3 : + (HOT)	 Balanced Line cable (Included)
Digital	DIGITAL OUTPUT (OPTICAL)	If your amplifier has an optical digital input terminal, you can connect the CD player to the amplifier using an optical optical fiber cable. The output level from this terminal cannot be changed. • Note: The OPTICAL terminal is protected with a cap. When connecting the cable to this terminal, set the Digital output on/off switch to ON . When this terminal is not in use, make sure to put the cap onto the terminal and set the Digital output on/off switch to OFF .	 Optical Fiber Cable (Option)

How to use XLR type connector

- Before connecting or disconnecting the input terminal, make sure that you turn the power off, in order to avoid damage to the speakers.
- When the output terminal of the preamplifier is pin type (Unbalanced), the XLR type connector cannot be used.

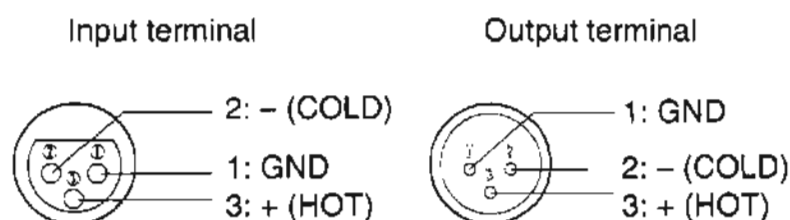

Input terminal

1. Connecting the input terminal (of the amplifier)

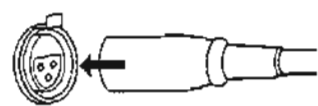

Match the pins and insert the terminal until you hear a "click". Ensure that it is secure by gently pulling it.

2. Disconnecting the input terminal

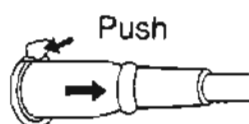

Pull out the cable while holding down the lever.

Output terminal

1. Connecting the output terminal (of the CD player)

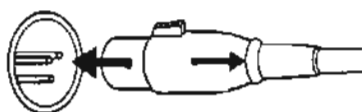

Match the pins and insert the terminal until you hear a "click". Ensure that it is secure by gently pulling it.

2. Disconnecting the output terminal

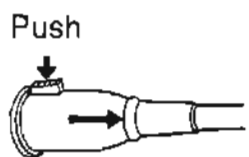

Pull out the cable (in the direction indicated by the arrow) while holding down the cable button.

Setting the voltage selector (worldwide models only)

Models without a voltage selector can only be used in areas where the power supply is the same as that of the CD player.

1. Determine the proper voltage for your area: 220V or 120V.
2. If the preset voltage is not proper for your area, insert a screwdriver into the groove in the switch. Slide the switch all the way to the right (120V) or to the left (220V), whichever is proper.

Supplying power to the CD player

Plug the AC power supply cord into a wall outlet.

Connecting the remote control cable

The remote control jacks are used to connect ONKYO products bearing the "RI" mark via the accessory remote control cable. The cassette deck with the "RI" mark can be operated using the remote control provided as an accessory with the DX-788F. When this unit is connected with ONKYO receivers or amplifiers bearing the "RI" mark, it can also be controlled by the remote control of that unit. (Refer to the operating instructions of your stereo receiver or amplifier for details.)

NOTE:

Do not connect the RI remote control cable to any amplifier or other unit that does not bear the ONKYO RI mark. If you do, you may damage the unit. This connection allows you to control both the CD player and the amplifier with the amplifier's remote control.

1. Find the supplied RI remote control cable.
2. Insert one end of the RI remote control cable into the RI remote control jack on the CD player. The upper and lower RI jacks have the same function, you may use either one.
3. Insert the remaining end of the RI remote control cable into the RI remote control jack on your ONKYO amplifier. The upper and lower RI jacks have the same function, you may use either one.

Connecting and using a timer

If you have an audio timer, it can be used to start the CD player at any time you desire.

1. Insert the AC power cord of the amplifier the CD player is connected to into the timer.
2. Insert the CD player AC power supply cord into the timer.
3. Turn on both the amplifier and the CD player.
4. Insert a compact disc in the compact disc tray of the CD player.
5. Set the time on the timer.

When the time you specified arrives, the CD player will play the compact disc automatically. For more details about the timer, please see the timer instructions.

Identifying buttons and indicators

Looking at the front panel and display window

Below is the location and names of the buttons and indicators on the front panel, the display window, and the remote control. For more information about the function of a particular button or indicator, please turn to the page listed in the brackets ([]) following each name.

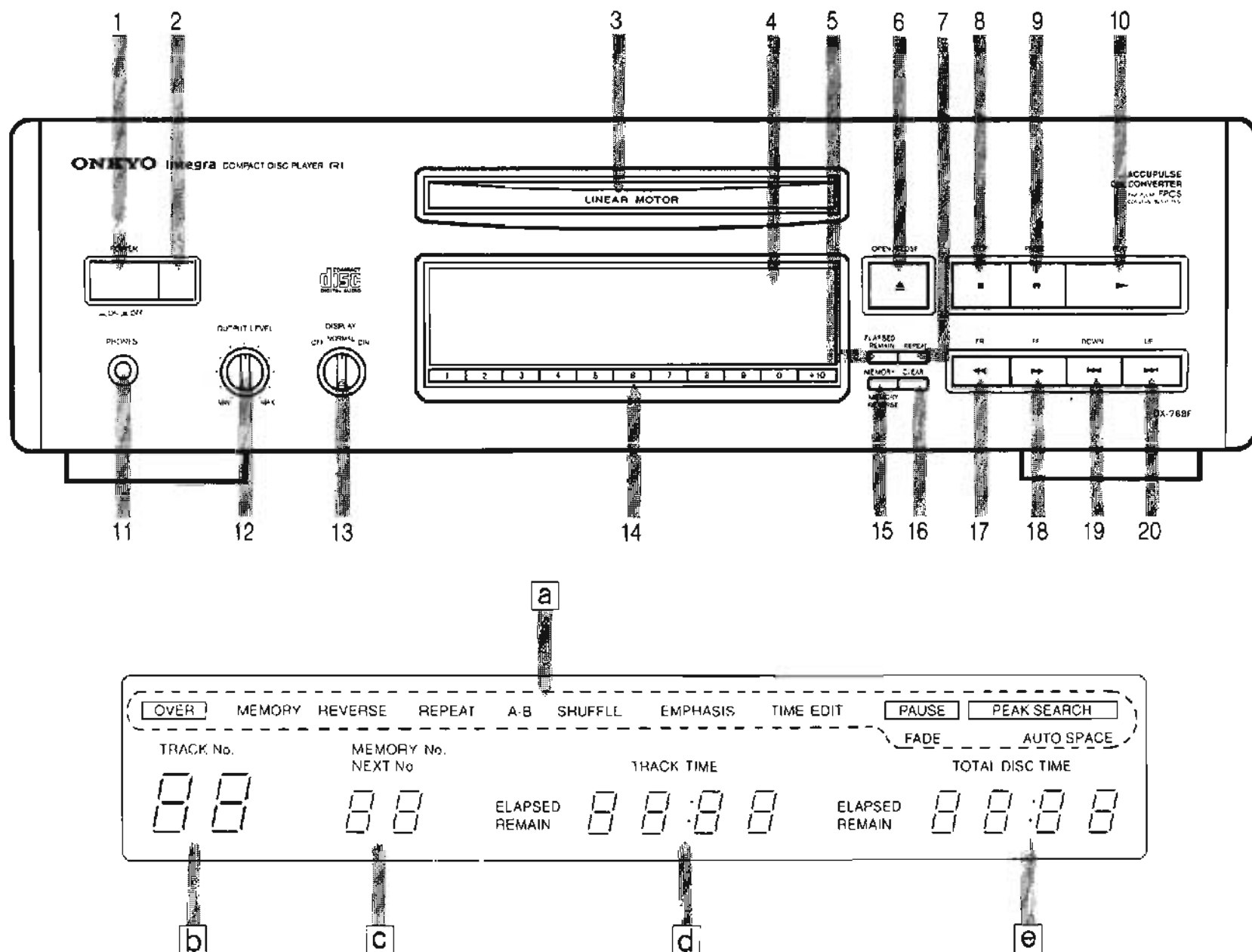

- | | |
|---|---|
| 1 Power Switch (POWER) [12] | 14 Number Buttons (1 – 9, 0) and Plus Ten Button (+10) [15] |
| 2 Remote Control Sensor [11] | 15 Memory Button (MEMORY/MEMORY REVERSE) [16] |
| 3 Disc Tray [12] | 16 Clear Button (CLEAR) [17] |
| 4 Display window [10] | 17 Fast Reverse Button (FR ◀◀) [14] |
| 5 Elapsed/Remaining Time Button (ELAPSED/REMAIN) [13] | 18 Fast Forward Button (FF ▶▶) [14] |
| 6 Open/Close Button (OPEN/CLOSE ▲) [12] | 19 Down Button (DOWN ◀◀) [14] |
| 7 Repeat Button (REPEAT) [15] | 20 Up Button (UP ▶▶) [14] |
| 8 Stop Button (STOP ■) [12] | |
| 9 Pause Button (PAUSE) [12] | a Function Display |
| 10 Play Button (PLAY ▶) [12] | b Track Number Display |
| 11 Headphone Jack (PHONES) | c Number Display |
| 12 Level Control Knob (OUTPUT LEVEL) [13] | d Track Time Display |
| 13 Display Switch (DISPLAY) [13] | e Total Disc Time Display |

Looking at the remote control

The buttons shown with the **RI** mark in the illustration below control functions which can only be accessed using the remote control.

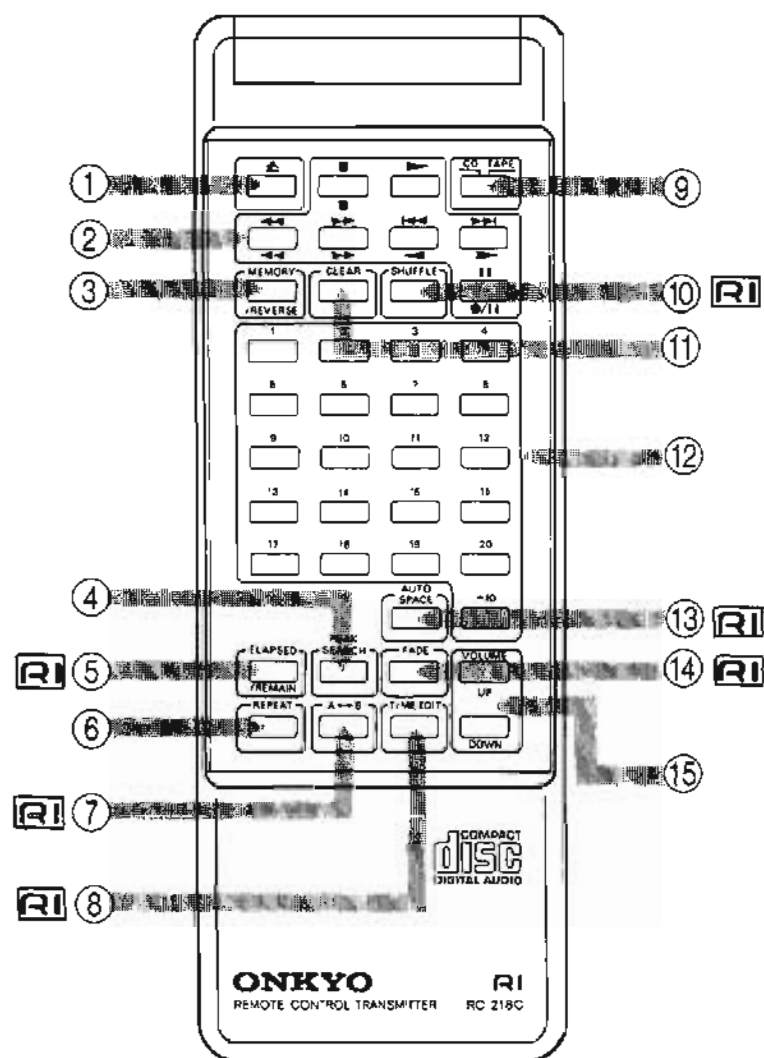

① Open/Close Button (\blacktriangle) [12]

② CD/Tape Operation Buttons

When the CD/TAPE selector switch is on CD. [12, 14]

- : Stop Button
- ▶ : Play Button
- ⏸ : Pause Button
- ⏮ : Fast Reverse Button
- ⏭ : Fast Forward Button
- ⏪ : Down Button
- ⏩ : Up Button

When the CD/TAPE selector switch is on Tape

- : Stop Button
- /⏸ : Rec/Pause Button
- ⏮ : Fast Rewind Button
- ▶ : Forward Play Button
- ⏪ : Reverse Play Button

③ Memory/Memory Reverse Button (MEMORY/REVERSE) [16]

④ Peak Search Button (PEAK SEARCH) [18]

⑤ Elapsed/Remaining Time Button (ELAPSED/REMAIN) [13]

⑥ Repeat Button (REPEAT) [15]

⑦ Block Repeat Button (A↔B) [15]

⑧ Time Edit Button (TIME EDIT) [19]

⑨ CD/TAPE Selector Switch

This switch should normally be set to the CD side. When a cassette deck bearing the ONKYO "RI" mark is connected to the remote control jacks of the DX-788F model, the deck can be controlled by this remote control. Set the CD/TAPE selector switch to TAPE. At this setting, the 6 functions (from ■ to ▶) listed above can be operated by remote control.

⑩ Shuffle Button (SHUFFLE) [15]

⑪ Clear Button (CLEAR) [17]

⑫ Number Buttons (0 – 20 and +10) [15]

⑬ Auto Space Button (AUTO SPACE) [18]

⑭ Fade Out Button (FADE) [18]

⑮ Volume Control Buttons (VOLUME DOWN/UP) [13]

Using the remote control

The following information will help you get optimal use from the remote control.

- Place the CD player away from direct bright light, which can prevent proper operation of the remote control.
- Make sure audio rack doors do not have colored glass. If the CD player is placed behind such a door, this may prevent proper remote control operation.
- Using other remote controls in the same room as the CD player remote control may cause interference.

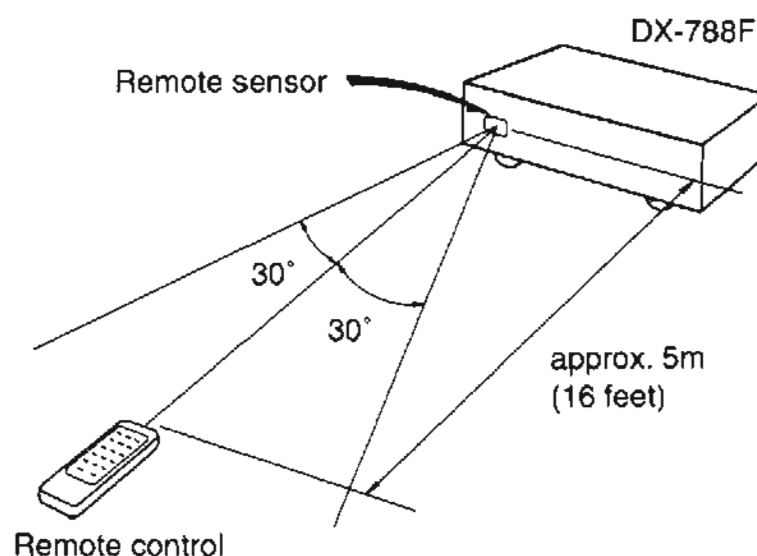

Playing CDs

Normal play

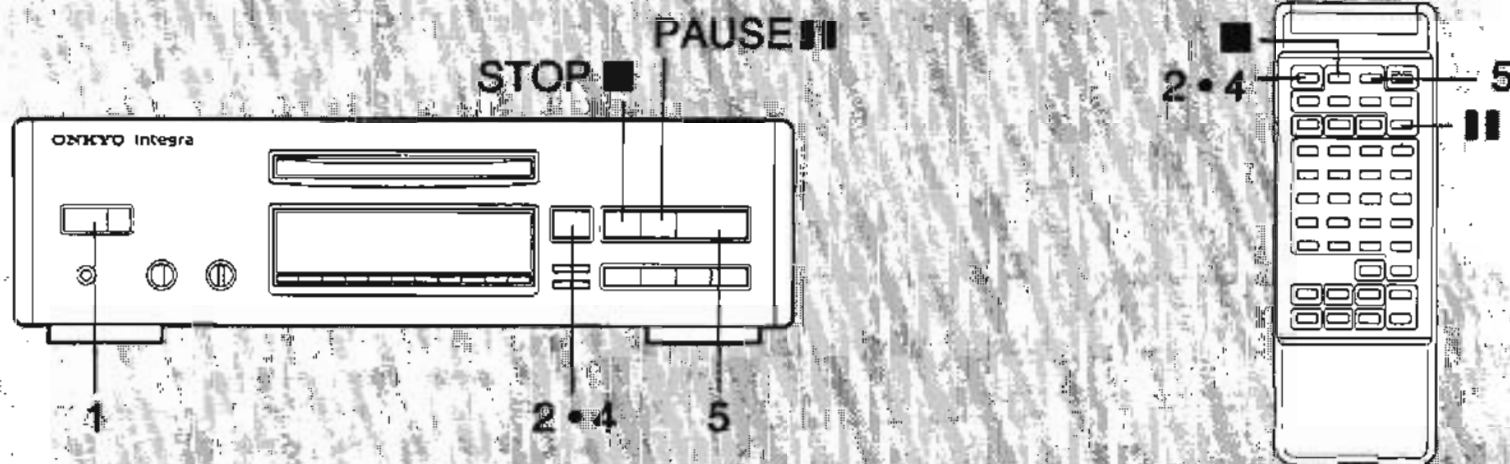

Easy operation (upper row of buttons: buttons on the front panel, lower row: buttons on the remote control)

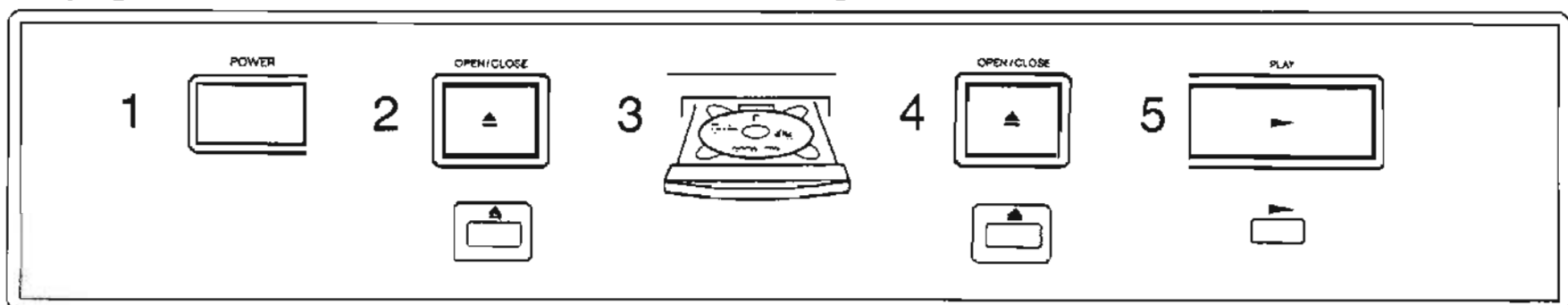

1. Press the **POWER** button.
 2. Press the **OPEN/CLOSE** button to open the disc tray.
 3. Put the disc in the disc tray, with the label side of the disc facing up.
 4. Press the **OPEN/CLOSE** button to close the disc tray.
 5. Press the **PLAY** button.
- The CD player will play the first track (track 1). If you want, you can skip step 4 by pressing the **PLAY** button instead of the **OPEN/CLOSE** button. The disc tray will close automatically and play track 1.

If the **DISC** indicator does not light when you insert a disc :

- The disc may be upside down in the tray. Press the **OPEN/CLOSE** button to open the disc tray. If you cannot read the label on the disc, turn the disc over, label side up.
- Moisture may have formed inside the CD player. Remove the CD disc from the disc tray and leave the power on for about one hour to evaporate the moisture.

Looking at the display

- Before starting playback after you have inserted a disc

When the number of tracks exceeds 20, the **OVER** indicator lights.



The total number of tracks on the disc. The total playing time of the disc.

- After you have started playback

Illuminated when playing the track which contains emphasis.

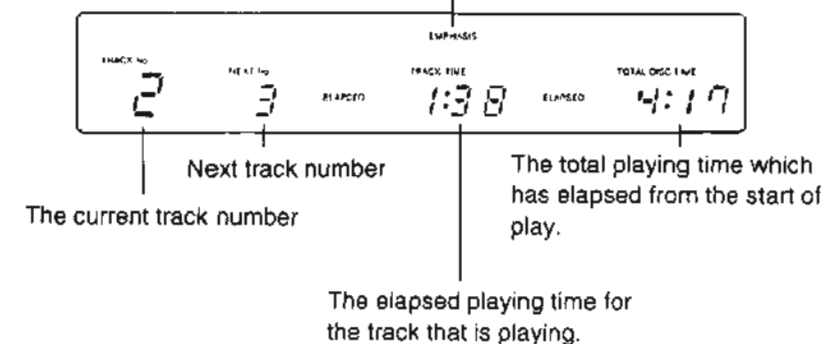

Pausing the disc temporarily

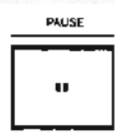

Press the **PAUSE** button to stop play temporarily. The CD will pause at the location where it was playing. Press the **PLAY** button to resume play.

Stopping play

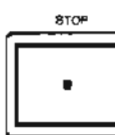

Press the **STOP** button to stop play.

Basic operation

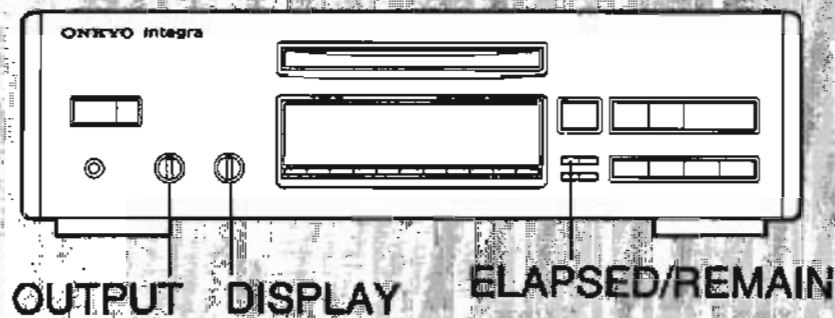

ELAPSED/
REMAIN

VOLUME
UP/DOWN

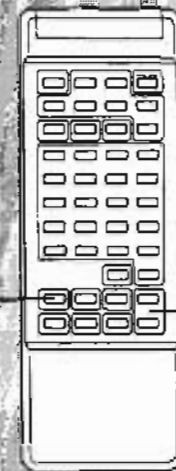

Volume adjustment

OUTPUT LEVEL



(CD player)
Use the **OUTPUT LEVEL** knob to adjust the output level (VARIABLE) and headphone output level.

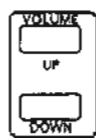

(Remote control)
Press **DOWN** button to lower the volume level and press **UP** button to increase.

When you press the UP/DOWN buttons on the remote control, the OUTPUT LEVEL knob on the front panel will move accordingly.

To change the brightness of the display

DISPLAY
OFF NORMAL DIM



Use the **DISPLAY** switch to change the brightness of the display.

OFF Turns the display completely OFF. When carrying out a button operation, the display will appear for a few seconds, then disappear again.

NORMAL : Normal brightness.

DIM : Dimmer than normal...this can be used when the display is too bright relative to the lighting in the room.

Checking the elapsed or remaining time

ELAPSED/
REMAIN



Press the **ELAPSED/REMAIN** button during play to check the elapsed time or the remaining time on the current track or entire disc.



Elapsed time

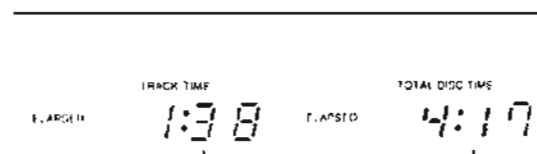

Shows how long the current track has been playing

Shows how long the entire disc has been playing

Remaining time



Shows how much time is left on the current track

Shows how much playing time is left for the entire disc

- Memory play: If you check the total remaining time while in memory play, the display shows the playing time remaining for all the tracks stored in memory.
- The TRACK TIME display will display the following for track numbers beyond 20: "-- : --".
- If the total remaining time of a CD exceeds 99 minutes, 59 seconds, "-- : --" will appear in the TOTAL DISC TIME indicator. This means merely that the remaining time is larger than 99 minutes, 59 seconds.

Playing CDs

Convenient features

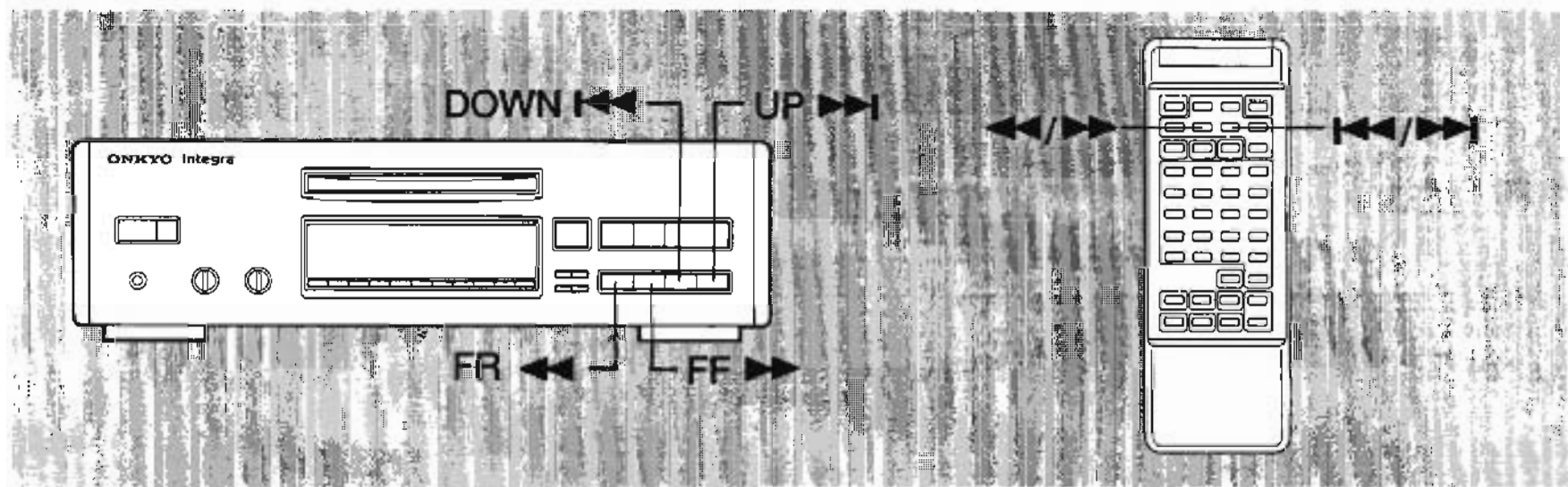

Moving forward or in reverse to a specific place on a track

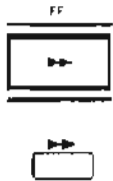

Press the **FF** button to fast forward the current track.

The disc will continue to fast forward while you hold down the **FF** button.

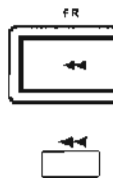

Press the **FR** button to fast reverse the current track.

The disc will continue to fast reverse while you hold down the **FR** button.

Release the **FF** or **FR** button when you reach the specific place on the track you want.

The CD player will automatically play when you release the **FF** or **FR** button. If you fast forward to the end of the disc, the CD will return to track 1 and then stop.

Memory play: If you press the **FF** button during memory play, the CD player will fast forward through the current track, then skip to the track stored on the next memory channel (MEMO CH) and resume play.

Shuffle play: If you press the **FF** button during shuffle play, the CD player will fast forward to the end of the current track, and then shuffle play will resume.

Memory play and shuffle play: If you press the **FR** button during memory play or shuffle play, the CD player will fast reverse to the beginning of the current track and then continues playing.

Returning to the beginning of the current track

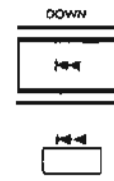

Press the **DOWN** button.

The CD player will stop playing the current track, return to the beginning of the track, and play the track again. Normal play will continue.

Memory play: The CD player will stop playing the current track, return to the beginning of the track, and play the track again. Then, memory play will continue.

Shuffle play: The CD player will stop playing the current track, return to the beginning of the track, and will play the track again. Then, shuffle play will continue.

Skipping to the next track

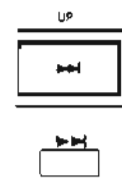

Press the **UP** button.

The CD player will stop playing the current track, then move to the beginning of the next track and play. Normal play will continue.

Memory play: The CD player will stop playing the current track, skip to the next track you have stored into memory, and play. Memory play will continue.

Shuffle play: The CD player will stop playing the current track and skip to another track randomly and resume shuffle play.

If you press the **DOWN** button during play, the CD player returns to the beginning of the current track and plays the track. If you press the button repeatedly, the CD player returns to the previous track and starts playing.

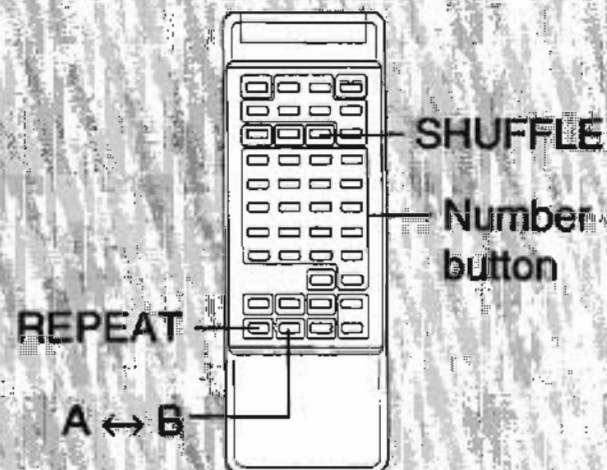
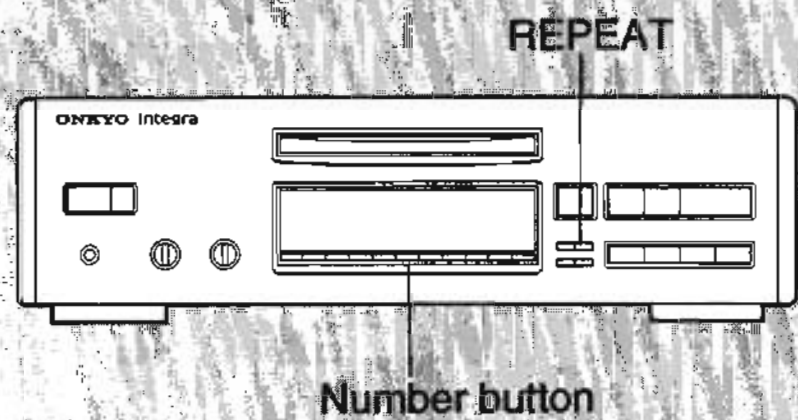

Playing a specific track

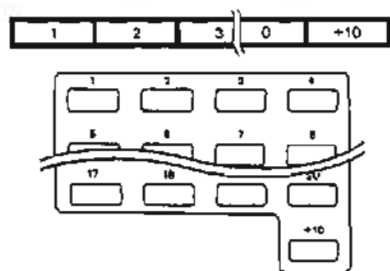

Press the **number button** that corresponds to the track number you want to play.

Please see the following table for examples of how to use the Number buttons.

Track number	Number buttons
Track 3	Press 3
Track 10	Press +10, then press 0
Track 25	Press +10 twice, then press 5

- When using the remote control to select a track number, you can directly input track numbers from 1 to 20 by pressing the appropriate button.

Playback will start automatically when the track number button is pressed.

Repeating all tracks on a disc



Press the **REPEAT** button at any time while the CD is playing.

The REPEAT indicator will light. When the last track on the disc has played, the CD player will return to the beginning of the disc and play all the tracks on the disc.

Press the **REPEAT** button twice to stop repeat play.

The REPEAT indicator in the display window will disappear. When the last track on the disc has played, the CD player will stop.

Press the REPEAT button to activate the repeat play mode. Repeat play can be used in conjunction with the normal, memory, and shuffle play modes. You can press this button before playing begins or in the middle of playing.

Using shuffle play

The shuffle play mode allows you to automatically mix up the order in which the tracks are played so that they play "randomly", in no particular order. You may also use shuffle play during memory play. Tracks stored in memory can be shuffled and played randomly.



Press the **SHUFFLE** button.

The CD player will play the tracks in a random order.

- The SHUFFLE indicator will light in the display window.
- In the Shuffle Play Repeat mode, when all of the tracks have been played back once, the order will be changed and the playing will be repeated with a different track progression.
- The SHUFFLE mode will be cancelled when the SHUFFLE button is pressed again, or when all of the tracks have been played back and stopped.
- The CD player will play a maximum of 99 tracks in shuffle play, then stop.

To repeat the block specified (Block Repeat)

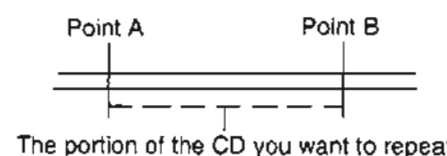

1. Press the **A ↔ B** button at Point A during playing.
A-B indicator flashes.
2. Press the **A ↔ B** button at Point B.
A-B indicator lights.
The section between A and B is played repeatedly.

To cancel the block repeat, press the **A ↔ B** button once more.

Disc play will then continue until the end of the disc.

NOTE: It is not possible to use the block repeat function during memory play, shuffle play, memory shuffle play and repeat play.

Using memory play

Storing a program into memory and play

Memory play allows you to decide in advance what tracks you would like to play and the order in which you would like to play them. You can select certain tracks that you want to listen to, skipping over the tracks you don't want to listen to.

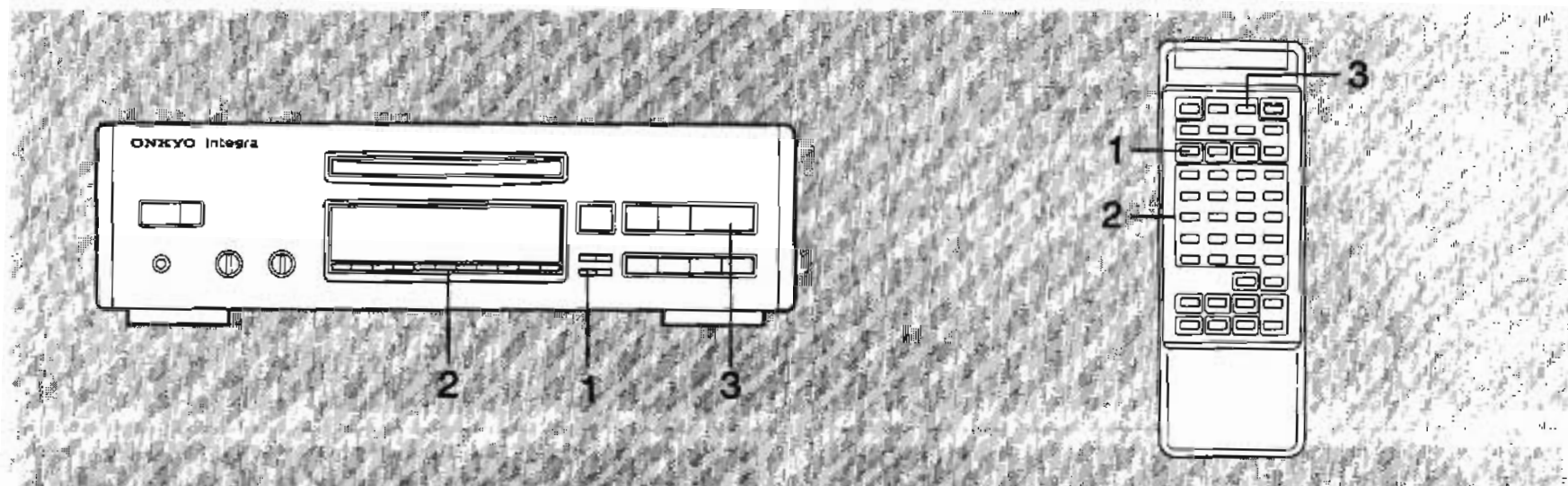

Easy operation (upper row of buttons: buttons on the front panel, lower row: buttons on the remote control)

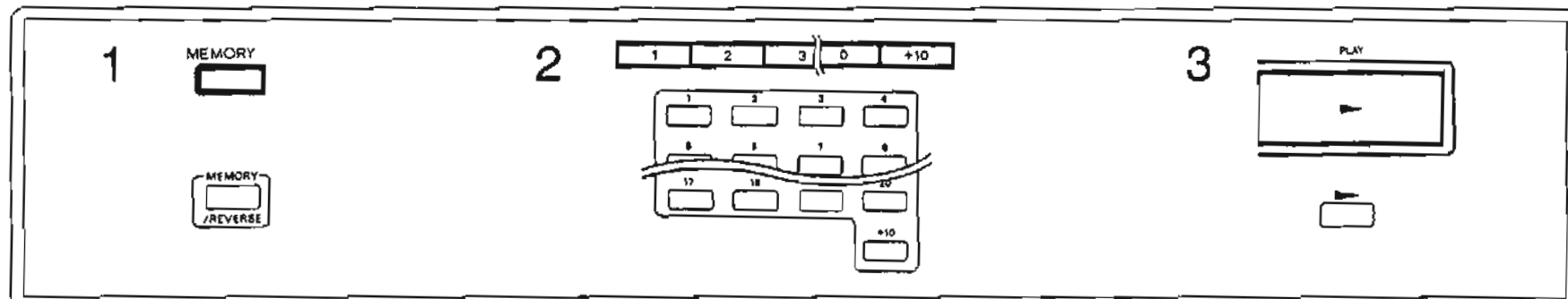

1. Press the **MEMORY** button.

If the MEMORY button is pressed during play, the track being played is stored into memory. Other tracks can also be stored into memory, see step 2, below.

2. Select a track you want to store into memory using the **Number buttons**.

Please refer to "Playing a specific track", p. 15.

To continue storing tracks into memory, press the **number button** of the next selection to be stored.

For example, if you chose tracks 5, 12, and 4, in that order,

CD player

Press **5** → **+10** **2** → **4**

Remote control

Press **5** → **12** → **4**

track 5 will be stored under MEMO CH 1, track 12 will be stored under MEMO CH 2, and track 4 will be stored under MEMO CH 3.

- Up to 20 tracks can be stored into memory by repeating this step.

3. Press the **PLAY** ► button.

The tracks will play in the order that you selected them.

When you press the MEMORY button, the indicator will light.

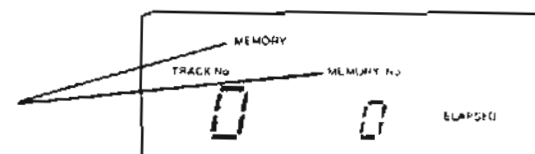

- If you try to add more than 20 tracks into memory, "FL" will flash momentarily on the display window to indicate that the memory channels are full.

To use the Memory Reverse Function

If there are tracks you don't want to hear or record, just program them into memory and press the MEMORY button again. All of the tracks you didn't program into memory will be played with a minimum of button touches.

For example, if you want to listen to all tracks on a CD, except for tracks 4, 5 and 12, store these into the memory, as described in the section on the left.

Press the **MEMORY** button.

- If you have made the Memory Reverse Function to program more than 20 tracks to be played, only the first 20 of these tracks will actually be played.
- To cancel the Memory Reverse mode, press the MEMORY button again.

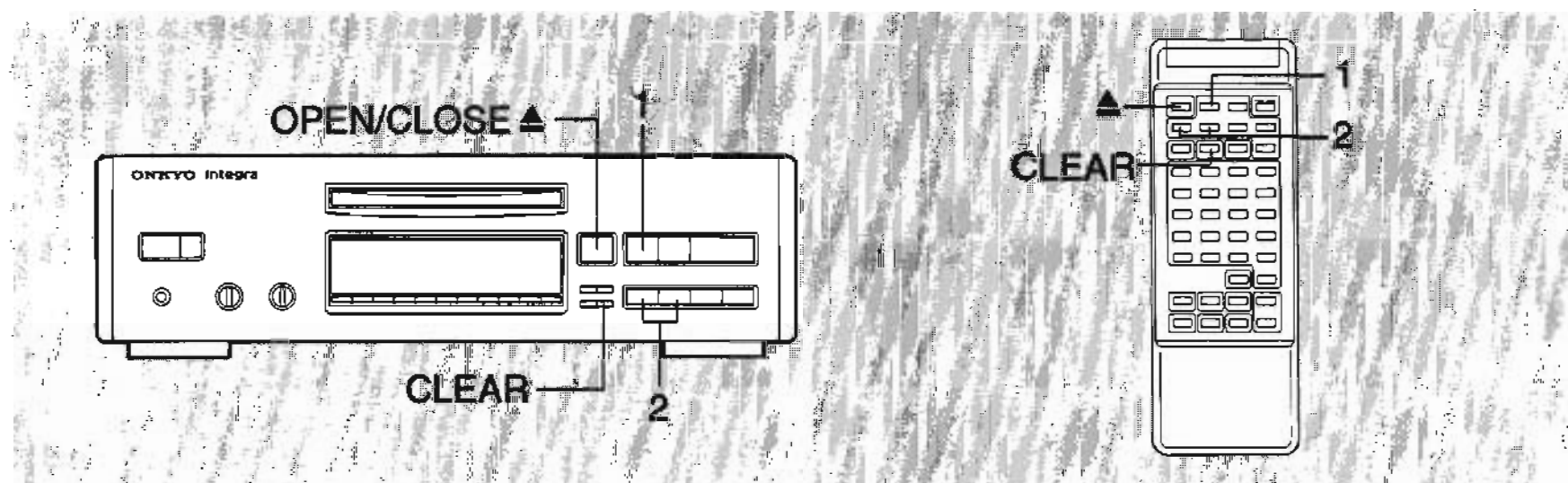

Checking what is stored in memory

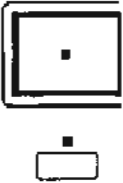
- 

Press the **STOP** ■ button if you are currently playing tracks stored in memory.

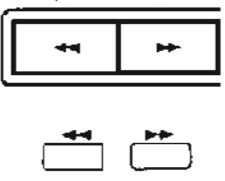
The last track stored in memory will light in the TRACK No. display and its memory channel will be displayed in the MEMORY No. display.
- 

Press the **FR** ◀◀ or **FF** ▶▶ buttons to view the other tracks stored in memory.

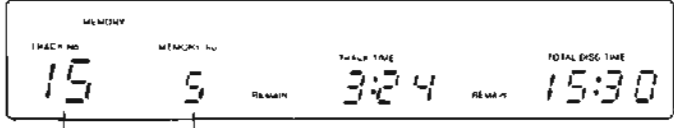

Track 15 is stored in MEMORY No.5

Clearing the tracks stored in memory

Clearing from the last track



Press the **CLEAR** button.

During memory play, the track that is currently playing and the tracks stored in memory channels (MEMORY No.) that played before the current track cannot be cancelled.

Clearing the whole of the program

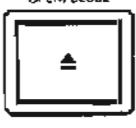

Press the **OPEN/CLOSE** ▲ button.

Looking at the display

- Storing tracks using the memory function
Example: Memorizing track number 4 in memory channel 1.

The selected track number.

The playback time for the selected track.



Memory channel

The total play time of selected tracks.

- Playing back using the memory function

The number of the track currently being played



Next track number in memory

Time elapsed in track currently playing

Total elapsed time

Convenient recording features

Peak Search Function

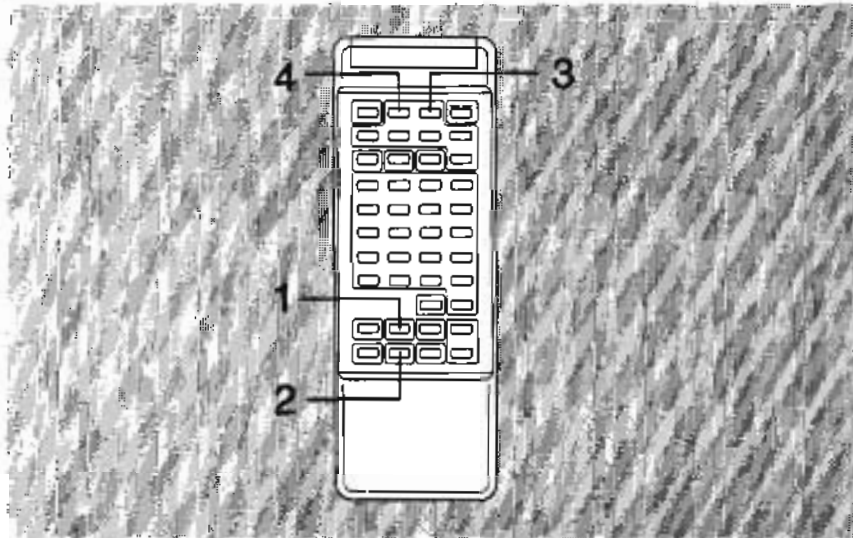

Easy operation (buttons on the remote control)

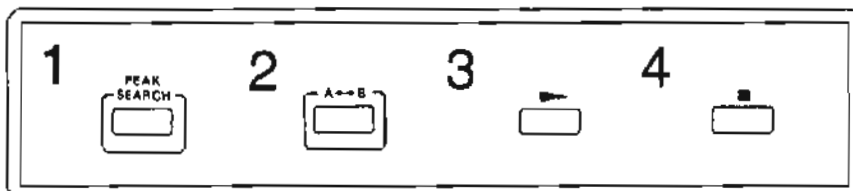

Depending on the disc in play, memorizing of a level which is different from the maximum audible level could occur. This is due to the CD player's microprocessor memorizing inaccurate information because of flaws in the disc itself, or recording conditions.

Under such circumstances, the recording level for the cassette tape may be entirely low, or else distortion or similar symptoms could arise on account of excessively high signal inputs. To avoid this, be sure to reset the recording level of the cassette deck in accordance with the symptoms.

1. Press the **PEAK SEARCH** button.

The player checks the disc for level. The **PEAK SEARCH** indicator will flash during this operation. After checking, the indicator will light.

2. Press the **A↔B** button.

The A-B indicator will light and **P** will flash on the MEMORY No., NEXT No. display.

3. Press the **PLAY** button.

Part of the track with the largest volume on the disc will be played repeatedly for 6 seconds. Refer to this level when recording the disc onto the cassette tape.

4. Press the **STOP** button.

This level is memorized until the OPEN/CLOSE button is pressed or the power is turned off. Pressing the **PEAK SEARCH** button will turn off the indicator and the level will be released from the memory. Pressing the **A↔B** button after pressing the **PLAY** button for performance will start the A↔B repeat operation.

Fade Out/Auto Space Function

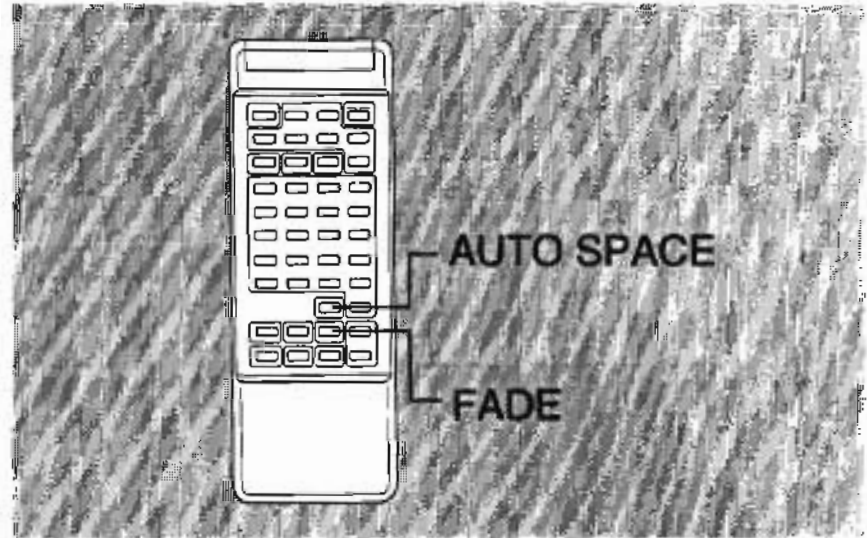

Fade Out Function

This function gradually decreases the volume. Set the volume knob to the maximum level first.



Press the **FADE** button during play.

Volume will decrease, with the **FADE** indicator flashing. The volume becomes minimum in approx. 10 seconds, and the performance will be stopped. This function is effective on the PHONES or VARIABLE OUTPUTS.

Auto Space Function

This function allows you to automatically insert 4 seconds of silence between tracks when playing back the CD in shuffle or memory modes. This is a very convenient feature when playing back a cassette recorded from the CD on a cassette player which can search for tracks.



Press the **AUTO SPACE** button.

The **AUTO SPACE** indicator will light.

To cancel this feature, press the **AUTO SPACE** button again (the indicator will go out).

Time Edit Function

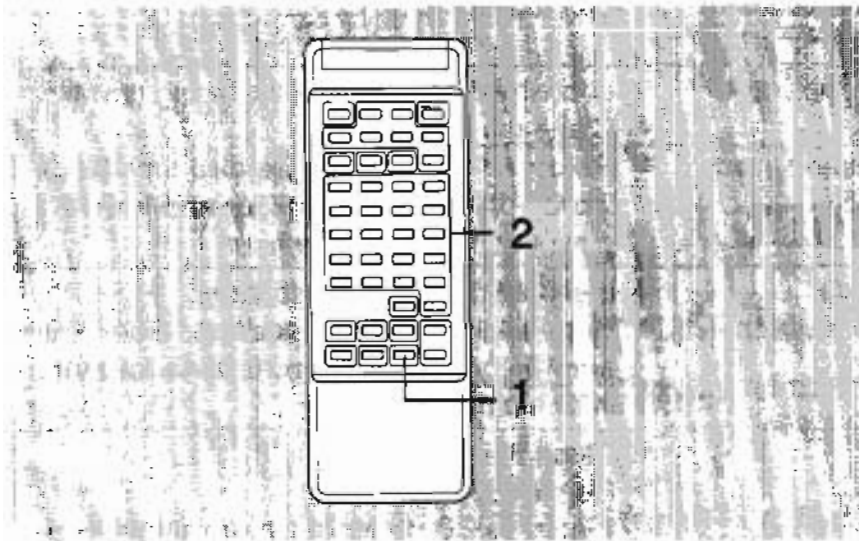

This function is convenient for copying your CDs to compact cassette. You specify the tape length, then the DX-788F calculates how many CD tracks can be recorded onto sides A and B. To avoid long unused sections of tape, always use a cassette that is just a few minutes longer than the total playing time of the CD.

Before using this function, stop playback and cancel the memory play function.

NOTE: The TIME EDIT function will not work with CDs that contain more than 20 tracks, or when the first CD track is longer than half of the specified tape length.

1. Press the **TIME EDIT** button.

The TIME EDIT indicator will flash and the TRACK TIME will display "C:--".

2. Use the **Number Buttons** to specify the tape length.

For example, to specify 46 for a C46 type cassette, press the +10 button four times, then press the 6 button once.

Press

Pressing the UP or DOWN button will carry out adjustment by one minute.

The DX-788F will calculate how many CD tracks can be recorded onto sides A and B. Tracks will be kept in the same order that they appear on the CD: 1, 2, 3, 4, etc. While the DX-788F is calculating, displays similar to the ones shown in the following example will appear. When the calculation is finished, the results will be shown.

TIME EDIT example: A CD is to be recorded onto a C46 cassette. Five tracks will fit on side A (total time 23 minutes), and four tracks on side B (total time 21 minutes and 34 seconds).

5	0	[46	2300
5	0	[46	2300
9	6	[46	2134
9	4	[46	2134
9	6	[46	2134

Changing the track order to optimize tape usage

If all the CD tracks will not fit onto the cassette,



press the **TIME EDIT** button again.

This time, the DX-788F ignores the CD track order and arranges the tracks in an order that will allow as many tracks as possible to be recorded onto the cassette. For example, side A tracks may be 1, 3, 4, 7, 8, side B tracks 2, 5, 6, 9, etc.

Repeating CD tracks to fill up the remaining tape

If, after executing the TIME EDIT function, there is still a lot of tape unused, you can add some more CD tracks to fill up the remaining tape. The tracks that you add will already have been included in the DX-788F's calculations, so added tracks will in fact be repeats.

1.



Use the **ELAPSED/REMAIN** button to specify which side (A or B) you want to add tracks.

2.

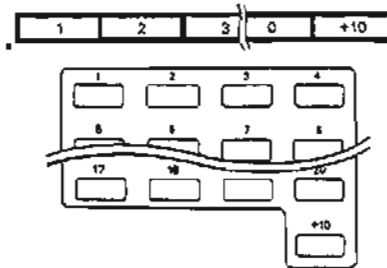

Use the **Number Buttons** to specify the tracks.

Tracks will be added at the end of the tape. If the specified track will not fit onto the cassette, the **OVER** indicator will flash 3 - 4 times, indicating that this track cannot be added.

Checking the track order

To check the order in which tracks will be recorded, press the FF or FR button repeatedly to step through the tracks.

Starting recording

1. Start your cassette player recording, then press the DX-788F's PLAY button. When all the tracks for side A have been recorded, pause mode will be engaged.
2. Turn over the cassette, start your cassette player recording, then press the DX-788F's PLAY button again. When all tracks have been recorded, or the STOP button is pressed, this function will be canceled.

Troubleshooting guide

Trouble	Cause	Remedy
POWER button is pressed, but power does not come on.	Power cord plug is not properly connected to AC outlet.	Insert plug firmly.
Disc is loaded in the disc tray, but play does not begin.	<ul style="list-style-type: none"> ● Disc is in the disc tray upside down. ● Disc is dirty. ● Moisture has accumulated inside the CD player. 	<ul style="list-style-type: none"> ● Load the disc with the label facing upward. ● Clean the disc. ● Remove the disc from the disc tray, place the CD player in a warm place and leave the power on for about one hour.
No sound	<ul style="list-style-type: none"> ● Incomplete connections. ● Improper input selector switch setting on amplifier. 	<ul style="list-style-type: none"> ● Insert all plugs firmly into jacks. ● Set switch to proper position. See your amplifier's operating instructions for more information.
Disc skipping	<ul style="list-style-type: none"> ● Disc is dirty. ● Disc is scratched. ● CD player has been bumped. 	<ul style="list-style-type: none"> ● Clean the disc. ● Replace the disc. ● Place the CD player in a more stable location.
Search time (when moving to a specific track) is extremely long.	<ul style="list-style-type: none"> ● Disc is dirty. ● Disc is scratched. 	<ul style="list-style-type: none"> ● Clean the disc. ● Use another disc.
Track numbers cannot be stored in the memory.	<ul style="list-style-type: none"> ● No disc in the tray. ● A track number not on the disc is being pressed. 	<ul style="list-style-type: none"> ● Load a disc into the tray. ● Use only the track numbers on the disc.

Specifications

Compact Disc Player

Model DX-788F

Signal readout system:	Optical non-contact	Wow and Flutter:	Below threshold of measurability
Reading rotation:	About 500 – 200 r.p.m. (constant linear velocity)	Output level:	2 volts r.m.s.
Linear velocity:	1.2 – 1.4 m/s	Power consumption:	34 watts
Error correction system:	Cross interleave Reed Solomon code	Power supply rating:	USA & Canadian models: AC 120V, 60Hz Worldwide model: AC 120V and 220V switchable 50/60Hz
D/A converter:	1 BIT PDM × 2 AccuPulse Quarz System	Dimensions (W × H × D):	455 × 130 × 364 mm 17-15/16" × 5-1/8" × 14-5/16"
Sampling frequency:	352.8 kHz (eight-times oversampling)	Weight:	8.9 kg, 19.6 lbs.
Number of channels:	2 (stereo)	Specifications and external appearance are subject to change without notice because of product improvements.	
Frequency response:	2 Hz – 20 kHz		
Total harmonic distortion:	0.0015% (at 1 kHz)		
Dynamic range:	100 dB		
Signal to noise ratio:	102 dB		
Channel separation:	102 dB (at 1 kHz)		

ONKYO CORPORATION

International Division: 2-1, Nisshin-cho, Neyagawa-shi, OSAKA 572, JAPAN
Tel: 0720-31-8133 Fax: 0720-34-1340

ONKYO U.S.A. CORPORATION

200 Williams Drive, Ramsey, N.J. 07446, U.S.A.
Tel: 201-825-7950 Fax: 201-825-8150

